

Glass Fiber Optics (CA-1410)

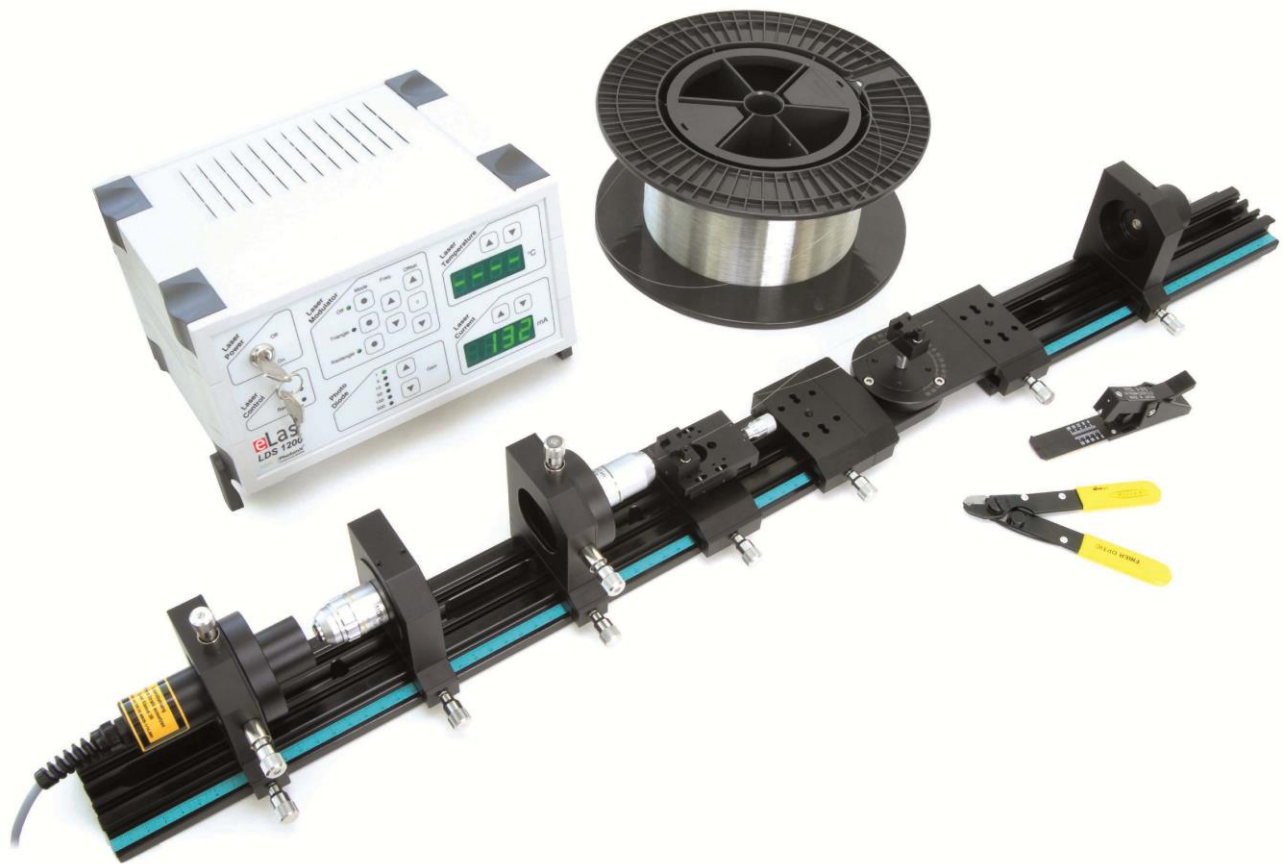

It was the communications technology that required an increase of data transfer rate and started the solution of this problem by sending signals down hair thin strands of glass fibers. It began about 40 years ago in the R&D labs (Corning, Bell Labs, etc.) and was first installed in Chicago in 1976. By the early 1980s, fiber networks connected bigger distances and in the 90s, TV started the use of fiber to enhance the reliability of their networks. Along the time, phone and Internet service, computers and LANs started using glass fibers. The continents became connected via glass fiber cable laid across the oceans. Applications in automobiles, aircrafts, ships and audio/video came up. Nowadays communications technology without glass fiber optics is unthinkable.

This education kit is excellently suited for a comprehensive introduction to theory and handling of glass fibers. The preparation of glass fibers by stripping and cleaving with appropriate tools are taught. The kit enables students coupling laser light into a multi- and singlemode fiber, respectively. The measurement of fiber parameters like numerical aperture and transmission losses are performed. All required mechanical, optical and electronic components for the setup are included. For time resolved measurements a 100 MHz oscilloscope is required and can be ordered as an option.

Educational Objectives of Investigation

- Characterization of Fibers
- Guiding of Light in Fibers
- Laser Diodes
- Stripping and Cleaving of Fibers
- Coupling Optics
- Communication via Glass Fiber

Setup and Components

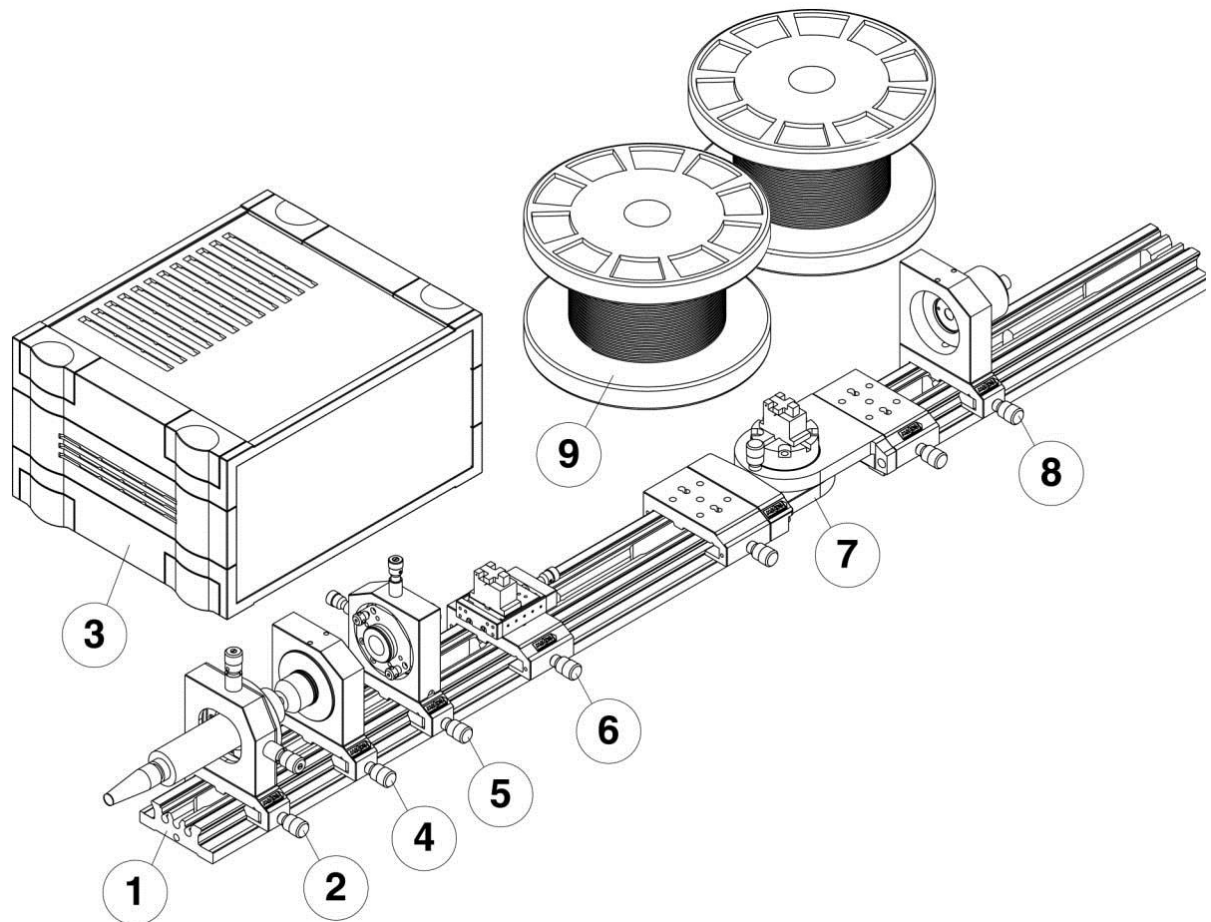

- 1 Set of 2 flat rails 500 mm with scale
- 2 Laser diode in XY-adjustment on carrier
- 3 Laser diode control unit LDS 1200
- 4 Collimator for laser diode beam
- 5 XY adjustment holder with fiber coupling optics on carrier
- 6 Fiber holder on translation stage on carrier
- 7 Fiber holder on articulated connector
- 8 PIN-photo detector in holder on carrier
- 9 2 x ~1000 m Optical glass fibers (single mode and multi mode)
- 10 Fiber cleaver and stripper (not shown)
- 11 IR-detector card 800-1600 nm (not shown)
- 12 Set of 3 BNC cables (not shown)
- 13 User manual (not shown)

Ordering Information

For ordering the Glass Fiber Optics experimental kit (CA-1410)
use ordering number: 490091410

Measurements and Handling

Some of the possible measurements are presented in the following list:

- **Laser diode output power versus current**

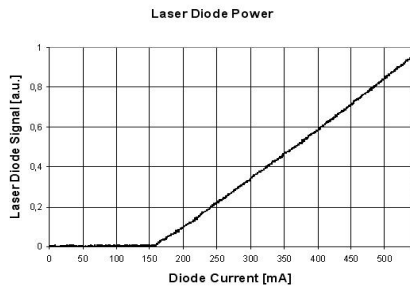

The relative output power of the laser diode used for optical pumping can be measured in dependence on the injection current. Parameters like laser threshold and slope efficiency are evaluated.

- **Fiber end preparation**

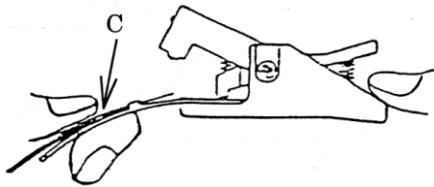

The preparation of the fiber ends for coupling laser light in and out of the fiber has to be trained. The correct handling of the fiber stripping and cleaving tools is trained in this step. The result are straight fiber surfaces for proper launch of laser light to the fiber.

- **Alignment of coupling optics**

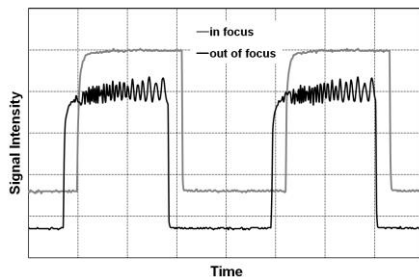

When launching laser light to the fiber a proper alignment of the beam with respect to the glass fiber end is very important. If the beam is not well focused onto the fiber core, portions of light will travel through the fiber via the fiber cladding causing a noisy structure of the light detected at the fiber end (lower signal). In case of a well focused beam the fiber delivers a smooth laser signal (upper curve).

- **Runtime of light in fibers**

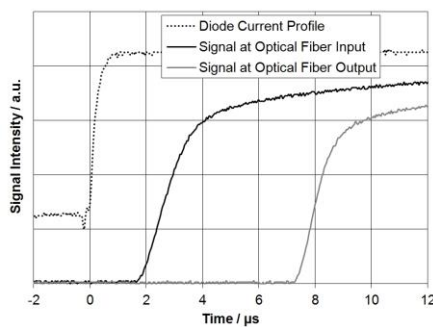

In the rectangular modulation mode of the laser diode the rising edge of the laser signal before and after entering the glass fiber is displayed on the left graph, together with the onset of the diode current switching profile. It is observed that the two light signals are delayed with respect to the diode current, but also with respect to each other. From the latter delay the runtime of the light signal in the glass fiber is measured and the fiber length (at known index of refraction) or the index of refraction of the fiber (at known fiber length) can be calculated.

- **Acceptance angle and numerical aperture**

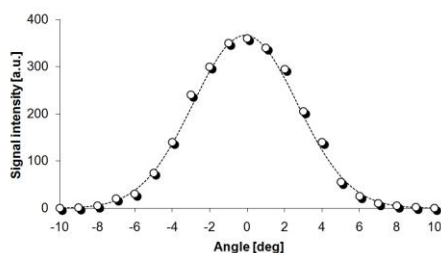

The photo detector unit is linked to the fiber coupling unit via an articulated connector (Part 7). This allows the detection of light coming out of the fiber end in an angle. A measurement of the light intensity as a function of the hinge angle is shown on the left graph. From this curve the acceptance angle of the fiber is quantified and the numerical aperture is calculated.